

SPECIFICATIONS & OPERATING INSTRUCTIONS

OPERATING SHUT HT.:	4-3/8" (111.1mm)	MIN. DIE CLEARANCE:	.006" (.15mm)
MIN. SHUT HEIGHT:	4-1/4" (107.9mm)	MAX. PUNCH DIAMETER:	.2500" (6.35mm)
UNIT OPEN HEIGHT:	4-7/8" (123.8mm)	MIN. PUNCH DIAMETER:	.0937" (2.38mm)
MATERIAL FEED CLEARANCE:	1/8" (3.2mm)	MAX. MATERIAL THICKNESS (MILD STEEL):	3/32" (2.4mm)
MAX. MATERIAL THICKNESS (MILD STEEL):	3/32" (2.4mm)	MAX. MATERIAL THICKNESS (STAINLESS STEEL):	1/16" (1.6mm)

HZ-3/4"

19mm width

COMPLETE ROUND UNITS

Model No.	Catalog No.	Price	Shipping Weight
HZ-3/4	10500		3.5 lbs.

To order a unit less punch and die, add the suffix "- LPD".

HZ-3/4 Unit for Round Holes Only

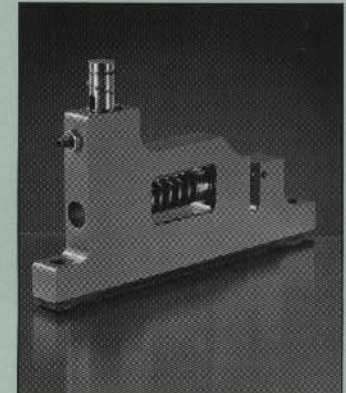
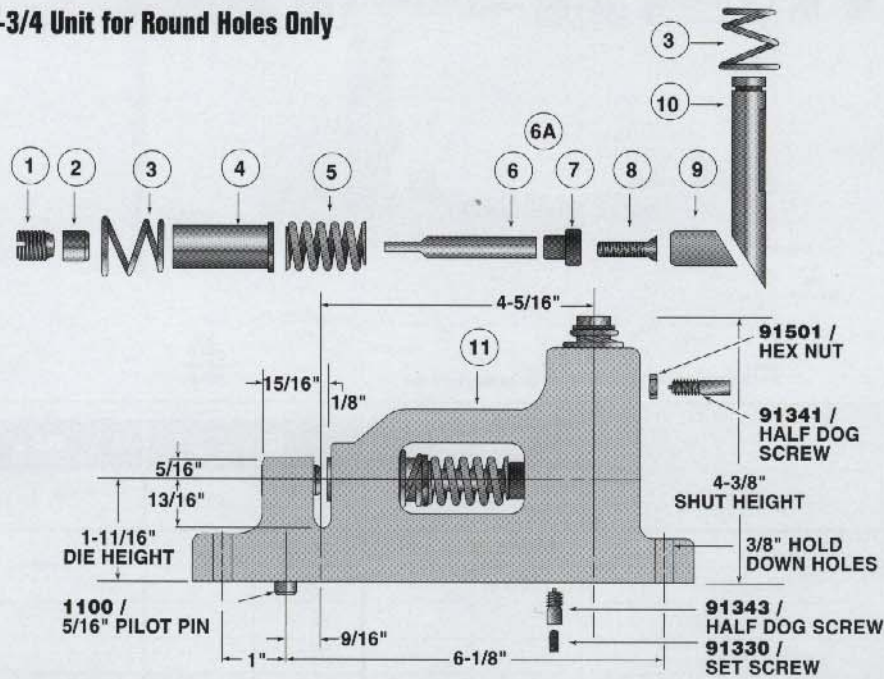

This series of Unipunch Units are designed for horizontal punching of holes in the vertical sides of flanges, rims and formed parts. In operation, the Press Ram depresses the Vertical Plunger forcing the punch horizontally through the material. On the up stroke of the Ram, the Stripping Spring removes the punch from the work piece. Equipped with a Pilot Pin in the base of the holders, these units are accurately located and set up on Templates to produce parts with the first stroke of the Press Ram.

Item No.	Description	Catalog No.	Price
1	Adjustment Screw	10522	
2	Round Die	10520	
3	Lifter Spring	10570	
4	Guide (Round)	10530	
5	Stripping Spring	3640	
6	Punch Only	3211	
6A	Punch w/ Head	10510	
7	Punch Head	10571	
8	Punch Screw FHSCS	91205	
9	Wedge	10573	
10	Plunger	10572	
11	Holder	10550	
KITS & SHIMS	Hardware Kit:	9380	
	Punch Shim:	N.A.	—
	Die Shim:	N.A.	—

ADD'L. PRODUCT

Exacta Precision Ltd. Toll Free Tel: 1.800.268.5573 Email Info@exactapunch.com

UNIPUNCH