

400 	SS-2 	SS-3 	SS-4 	SS-5 	SS-6 	795 	SS-8 	SS-9 	SS-10
SS-87 	0°								SS-11
SS-86 	<h1>EXACTA</h1>   <h2>TRUMPF® STYLE Tooling</h2>								SS-12
SS-42 									SS-13
SS-40 									SS-14
SS-38 									SS-15
SS-37 									SS-16
SS-36 									SS-17
SS-35 									SS-18
SS-34 									SS-19
SS-33 									SS-20
SS-32 									SS-21
SS-31 	90°								SS-22
SS-30 	<h3>CAT #X604</h3>  <h3>180°</h3>								SS-23
SS-29 									SS-24
SS-28 									SS-25
SS-27 									SS-26
SS-25 									SS-27

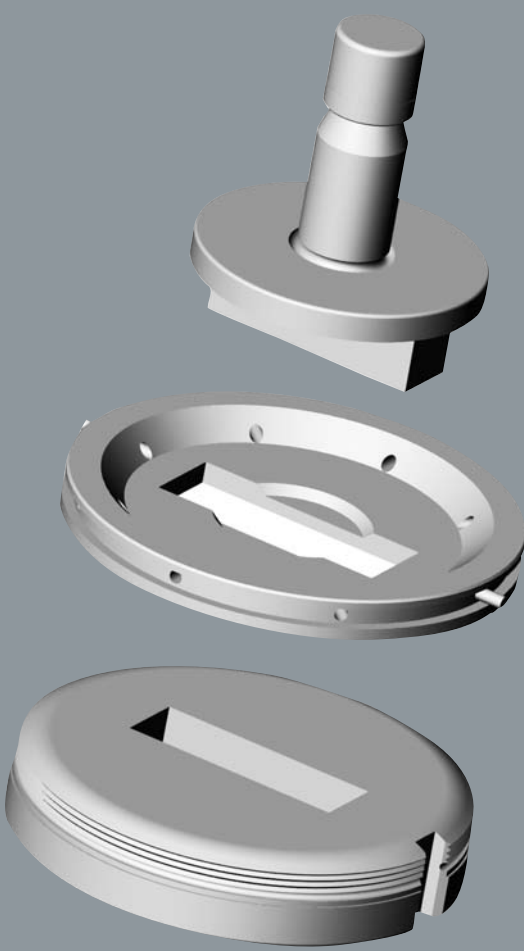
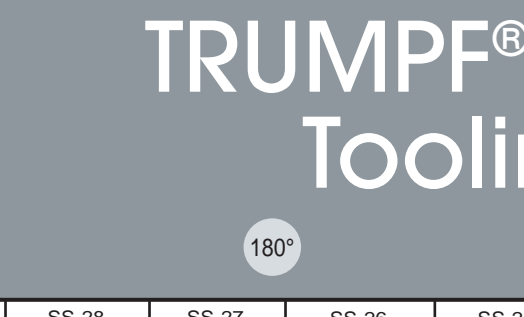

Index

General Information	1	Multi-Tool Punches, Dies and Strippers . . .	8-9
Round Punches	2	Heavy Duty Tooling	10
Round Dies and Strippers	3	<i>NEW</i> Self Aligning Punches	11
Shape Punches	4	Tooling Accessories	12-13
Shape Dies and Strippers	5	Forming Tools	Back Cover
Minimatic 100/Trumatic120 Tooling	6-7	<i>Minimatic 100/Trumatic120 are Registered Trademarks of TRUMPF GmbH & Co.</i>	

Required Ordering Information

1. Type of **MACHINE & MODEL**.
2. Type of **TOOL** (eg. punch, die, stripper, etc.) and **PART NUMBER** if available.
3. **SHAPE** of Tool (round, rectangle, square, etc.) specials see front and back cover or supply drawing.
4. **DIMENSIONS** of **SHAPE** - looking at face of the die or component part.
5. **DIE CLEARANCE** required - or **TYPE** of **MATERIAL** and **THICKNESS** being punched.
6. **KEYING LOCATION** - if other than standard.
7. If **FORMING** - up or down.

STRIPPERS

These tool components provide proper stripping action for a given punch and die setup.

DIE CLEARANCE

Is the total space between punch and die. Die clearance is governed by the thickness and tensile strength of work piece material. Refer to chart on back cover.

PUNCHES

Can be supplied with or without shear.

WHISPER SHEAR®

Benefits include quieter operation, reduced punching force requirements, lower stress concentrations.

Whisper Shear is a Trademark of TRUMPF GmbH&Co.

To Order

ONTARIO

EXACTA PRECISION PRODUCTS LTD.

3115 Kennedy Road
Scarborough, Ontario, Canada
M1V 4Y1

Telephone: (416) 291-1942
Toll Free: 1-800-268-5573
Fax: (416) 291-8387
Toll Free Fax: 1-800-668-9314

QUEBEC & MARITIMES

PRODUITS DE PRÉCISION EXACTA LTÉE.

5965 Chemin St. François
Ville St. Laurent, Québec
H4S 1B6

Téléphone: (514) 333-0146
(Sans Frais) 1-800-361-6810
Québec, N.B. - P.E.I. & N.S. (Toll Free)
Télécopieur (514) 333-0147

Email: info@exactapunch.com • Website: www.exactapunch.com

General Information

Standard Shapes and Shape Codes

100 OBLONG	200 SQUARE	300 RECTANGLE	400 SINGLE D	500 FLATTED ROUND	650 HEXAGON	665 QUAD D	670 OCTAGON	680 EQUALATERAL	795 LONG D

SPECIFY DIE INDEXING REQUIRED ON 400, 680 AND 795

Top View of Front of Machine

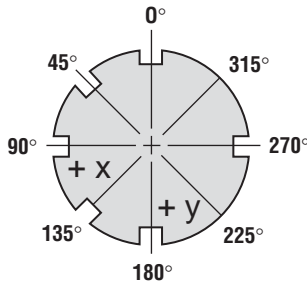

WHEN ORDERING TOOLING WITH KEYING OTHER THAN STANDARD SPECIFY SHAPE LOCATION BY DEGREE USING THIS DIAGRAM

Standard Keying of Dies

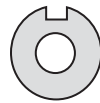

Round Dies
Keyway at 0°

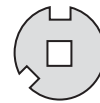

Square, Quad and Octagon Dies
Keyways at 0° and 135°

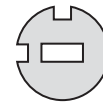

All Other Dies
Keyways at 0° and 90°



Non-Symmetrical Special Shapes
4 Keyways

Dies are keyed as above unless otherwise specified or for machines with rotational capability then one key is provided.

PUNCH DATA

XP1	LENGTH	2.36 (60 MM)	OAL
XP2	LENGTH	2.36 (60 MM)	OAL
XP3	LENGTH	2.36 (60 MM)	OAL
XP4 - XP10	LENGTH	2.93 (74 MM)	OAL
*XP4WS - XP10WS	LENGTH	3.032 (77 MM)	OAL

*WS = WHISPER SHEAR®

Whisper Shear is a Trademark of TRUMPF GmbH&Co

DIE DATA

#1 DIE	2.362	OD (60 MM)	.709	HIGH (18 MM)
#2 DIE	3.94	OD (100 MM)	.787	HIGH (20 MM)
#3 DIE	5.90	OD (150 MM)	1.181	HIGH (30 MM) <i>(ONLY FOR USE IN SELECTED MACHINES)</i>

STRIPPER DATA

XS1	3.933	OD (99.8 MM)	.413	HIGH (10.5 MM)	NON-KEYED
XS2	6.000	OD (152.4 MM)	.750	HIGH (19.0 MM)	NON-KEYED
XSG1	3.933	OD (99.8 MM)	.413	HIGH (10.5 MM)	KEYED
XSG2	6.000	OD (152.4 MM)	.750	HIGH (19.0 MM)	KEYED
XSGT1	3.933	OD (99.8 MM)	.433	HIGH (10.9 MM)	KEYED THICK
XSTC1	3.933	OD (99.8 MM)	.433	HIGH (10.9 MM)	TC STYLE

ALL STRIPPERS SUPPLIED PUNCH SIZE PLUS .060 (1.55 MM) UNLESS OTHERWISE SPECIFIED.



Round Punches

PUNCHES PREMIUM HIGH SPEED STEEL

Insert Style

For Insert Holders see page 13.

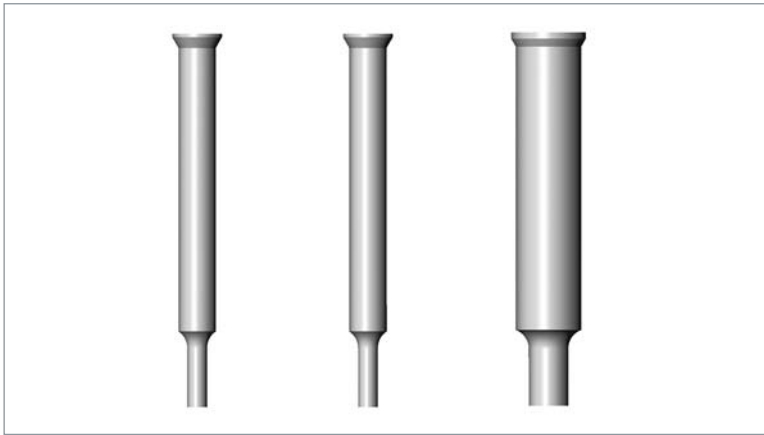

PART NO.	RANGE "P"	
	INCH	METRIC
*XP1	.031 - .062	0.78 - 1.58
*XP2	.063 - .234	1.59 - 5.95
*XP3	.235 - .406	5.96 - 10.32

*SUPPLIED AS STANDARD UNLESS OTHERWISE SPECIFIED

Full Body - Flat Face

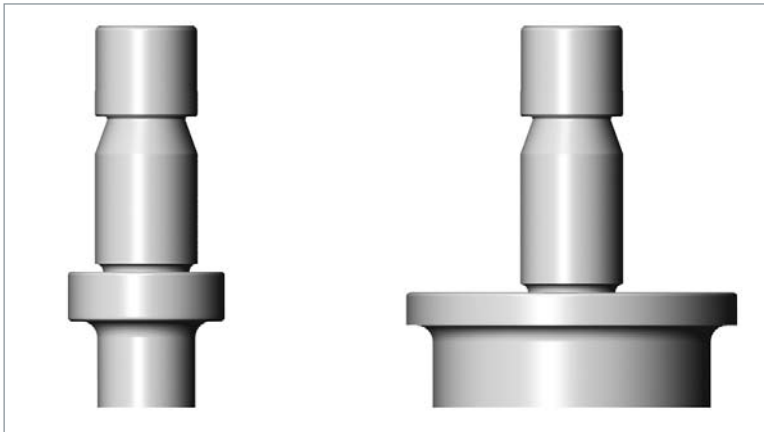

PART NO.	RANGE "P"	
	INCH	METRIC
*XP4	.062 - 1.181	1.58 - 30.01
XP5	1.182 - 1.500	30.02 - 38.11
XP6	1.501 - 2.015	38.12 - 51.19
XP7	2.016 - 2.515	51.20 - 63.89
XP8	2.516 - 2.760	63.90 - 70.11
XP9	2.761 - 3.015	70.12 - 76.59
XP10	3.016 - 4.125	76.60 - 104.78

*SUPPLIED AS STANDARD .407 AND UP UNLESS OTHERWISE SPECIFIED

Full Body - Whisper Shear®

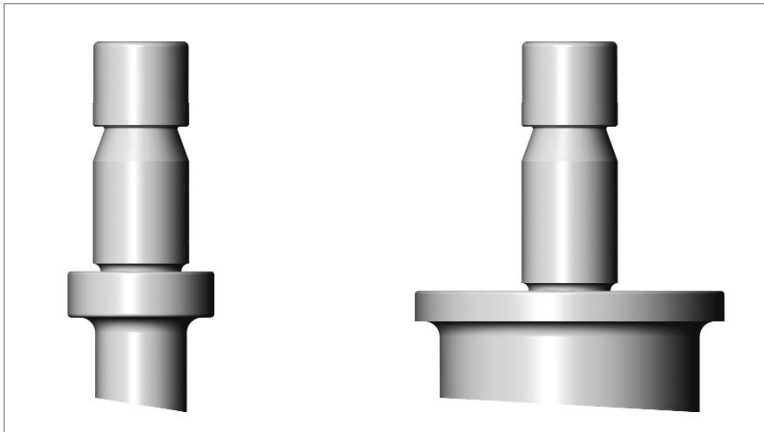

PART NO.	RANGE "P"	
	INCH	METRIC
XP4WS	.062 - 1.181	1.58 - 30.01
*XP5WS	1.182 - 1.500	30.02 - 38.11
*XP6WS	1.501 - 2.015	38.12 - 51.19
*XP7WS	2.016 - 2.515	51.20 - 63.89
*XP8WS	2.516 - 2.760	63.90 - 70.11
*XP9WS	2.761 - 3.015	70.12 - 76.59
*XP10WS	3.016 - 4.125	76.60 - 104.78

*SUPPLIED AS STANDARD UNLESS OTHERWISE SPECIFIED

Whisper Shear is a Trademark of TRUMPF GmbH&Co.

For Heavy Punching see page 10.

Round Dies



Size 1 - Small

PART NO.	RANGE "P"	
	INCH	METRIC
XD1	.035 - 1.260	0.88 - 32.01

Size 2 - Medium

PART NO.	RANGE "P"	
	INCH	METRIC
XD2	1.261 - 3.032	32.02 - 77.02

Size 3 - Large

(Only for Use In Selected Machines)

PART NO.	RANGE "P"	
	INCH	METRIC
XD3	3.033 - 4.213	77.03 - 107.01

Round Strippers



Non-Keyed

PART NO.	RANGE "P"	
	INCH	METRIC
XS1	.031 - 3.090	.78 - 78.49
XS2	3.091 - 4.125	78.50 - 104.78

Keyed

PART NO.	RANGE "P"	
	INCH	METRIC
XSG1	.031 - 3.090	.78 - 78.49
XSG2	3.091 - 4.125	78.50 - 104.78

Keyed Thick

PART NO.	RANGE "P"	
	INCH	METRIC
XSGT1	.031 - 3.090	.78 - 78.49

TC Style

PART NO.	RANGE "P"	
	INCH	METRIC
XSTC1	.031 - 3.090	.78 - 78.49



Shape Punches

PUNCHES PREMIUM HIGH SPEED STEEL

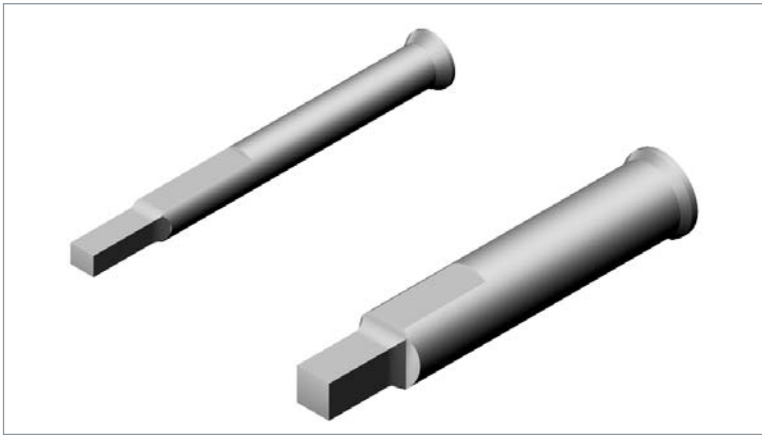

Insert Style

PART NO.	RANGE - MAXIMUM ACROSS CORNER DIM.		PRICE
	INCH	METRIC	
XPZ2 ___	.031 - .234	.78 - 5.95	
XPZ3 ___	.235 - .406	5.96 - 10.32	

SPECIFY SHAPE CODE IN PLACE OF ___

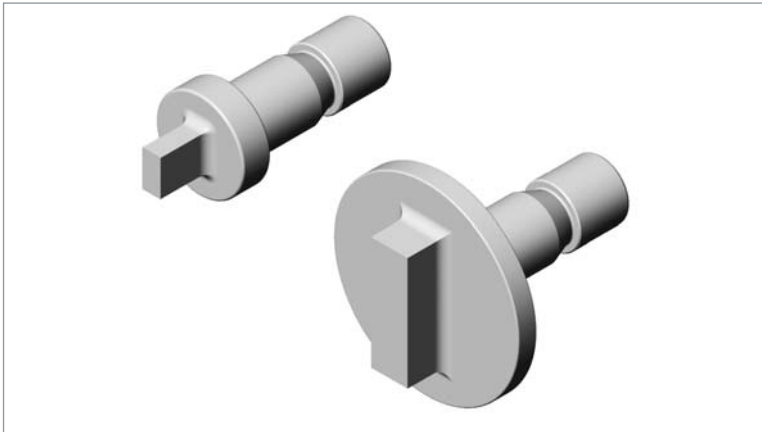

Flat Face

PART NO.	RANGE - MAXIMUM ACROSS CORNER DIM.		PRICE
	INCH	METRIC	
*XPZ4 ___	.062 - 1.181	1.57 - 30.01	
XPZ5 ___	1.182 - 1.500	30.02 - 38.11	
XPZ6 ___	1.501 - 2.015	38.12 - 51.19	
XPZ7 ___	2.016 - 2.515	51.20 - 63.89	
XPZ8 ___	2.516 - 2.760	63.90 - 70.11	
XPZ9 ___	2.761 - 3.015	70.12 - 76.59	
XPZ10 ___	3.016 - 4.125	76.60 - 104.78	

*SUPPLIED AS STANDARD UNLESS OTHERWISE SPECIFIED
SPECIFY SHAPE CODE IN PLACE OF ___

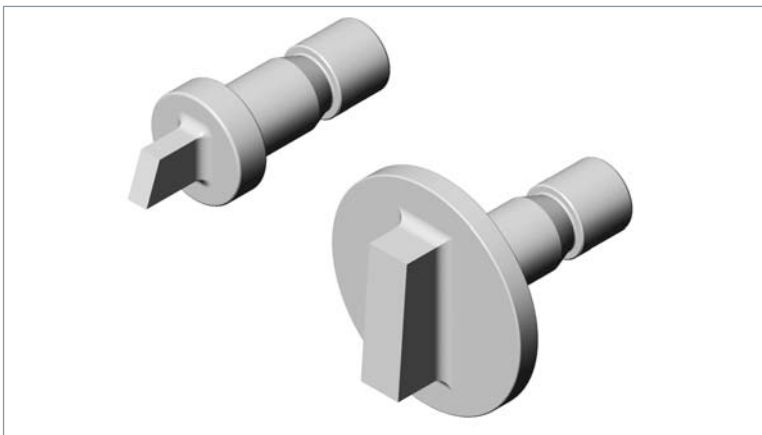

Whisper Shear®

PART NO.	RANGE - MAXIMUM ACROSS CORNER DIM.		PRICE
	INCH	METRIC	
XPZ4WS ___	.062 - 1.181	1.57 - 30.01	
*XPZ5WS ___	1.182 - 1.500	30.02 - 38.11	
*XPZ6WS ___	1.501 - 2.015	38.12 - 51.19	
*XPZ7WS ___	2.016 - 2.515	51.20 - 63.89	
*XPZ8WS ___	2.516 - 2.760	63.90 - 70.11	
*XPZ9WS ___	2.761 - 3.015	70.12 - 76.59	
*XPZ10WS ___	3.016 - 4.125	76.60 - 104.78	

*SUPPLIED AS STANDARD UNLESS OTHERWISE SPECIFIED
SPECIFY SHAPE CODE IN PLACE OF ___

Whisper Shear is a Trademark of TRUMPF GmbH&Co.

For Heavy Punching see page 10.

NEW for Self Aligning Punches see page 11.

Shape Dies

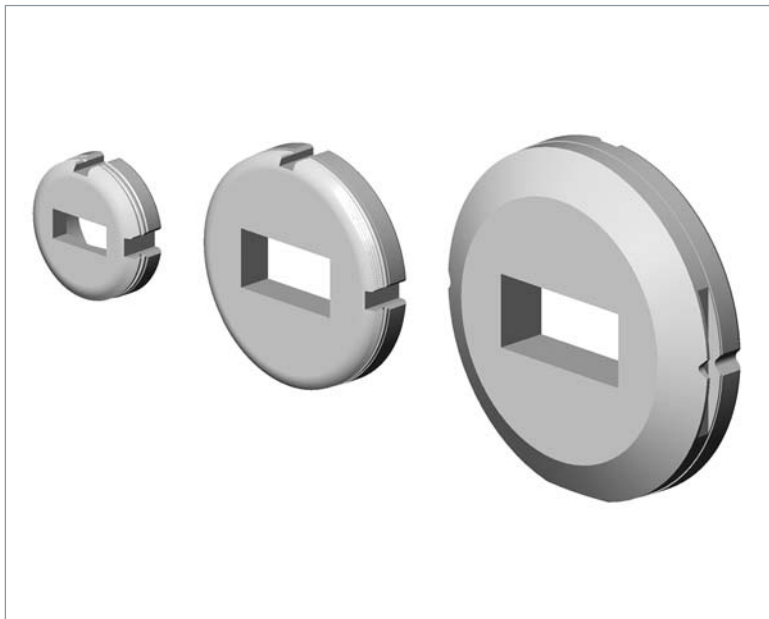

Size 1 - Small

PART NO.	RANGE - MAXIMUM ACROSS CORNER DIM.	
	INCH	METRIC
XDZ1 ___	.066 - 1.260	1.67 - 32.01*
NOTE: FOR 1 KEYWAY ONLY - PART# XDZ1-R ___		
SPECIFY SHAPE CODE IN PLACE OF ___		

Size 2 - Medium

PART NO.	RANGE - MAXIMUM ACROSS CORNER DIM.	
	INCH	METRIC
XDZ2 ___	1.261 - 3.032	32.02 - 77.02
NOTE: FOR 1 KEYWAY ONLY - PART# XDZ2-R ___		
SPECIFY SHAPE CODE IN PLACE OF ___		

Size 3 - Large

(Only for Use In Selected Machines)

PART NO.	RANGE - MAXIMUM ACROSS CORNER DIM.	
	INCH	METRIC
XDZ3 ___	3.033 - 4.213	77.03 - 107.01
SPECIFY SHAPE CODE IN PLACE OF ___		

Shape Strippers



Non-Keyed

PART NO.	RANGE - MAXIMUM ACROSS CORNER DIM.	
	INCH	METRIC
XSZ1 ___	.062 - 3.090	1.58 - 78.49
XSZ2 ___	3.091 - 4.125	78.50 - 104.78
SPECIFY SHAPE CODE IN PLACE OF ___		

Keyed

PART NO.	RANGE - MAXIMUM ACROSS CORNER DIM.	
	INCH	METRIC
XSGZ1 ___	.062 - 3.090	1.58 - 78.49
XSGZ2 ___	3.091 - 4.125	78.50 - 104.78
SPECIFY SHAPE CODE IN PLACE OF ___		

Keyed Thick

PART NO.	RANGE - MAXIMUM ACROSS CORNER DIM.	
	INCH	METRIC
XSGTZ1 ___	.062 - 3.090	1.58 - 78.49
SPECIFY SHAPE CODE IN PLACE OF ___		

TC Style

PART NO.	RANGE - MAXIMUM ACROSS CORNER DIM.	
	INCH	METRIC
XSTCZ1 ___	.062 - 3.090	1.58 - 78.49
SPECIFY SHAPE CODE IN PLACE OF ___		

Standard Shapes and Shape Codes

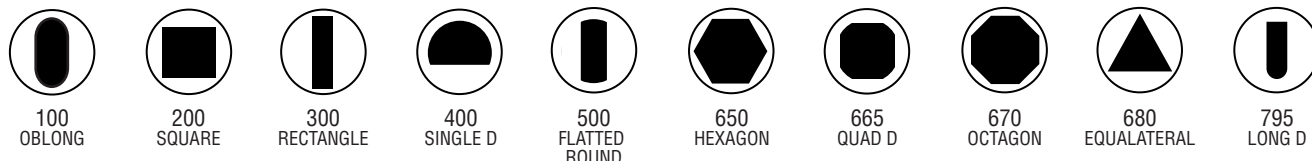

SPECIFY DIE INDEXING REQUIRED ON 400, 680 AND 795



Minimatic 100 / Trumatic 120® Tooling

Round Tooling

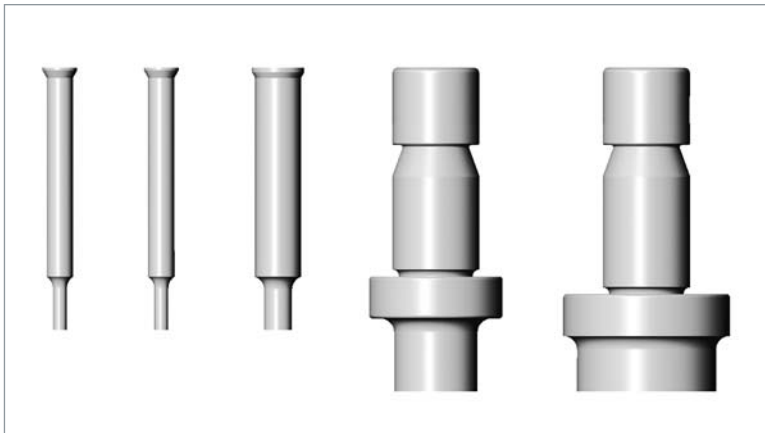

Round Punch

PART NO.	RANGE "P"	
	INCH	METRIC
* XP1	.031 - .062	.78 - 1.58
* XP2	.063 - .234	1.59 - 5.95
* XP3	.235 - .406	5.96 - 10.32
**XP4	.062 - 1.181	1.58 - 30.01
XP5WS	1.182 - 1.500	30.02 - 38.11

* SUPPLIED AS STANDARD UNLESS OTHERWISE SPECIFIED
**SUPPLIED AS STANDARD .407 AND UP UNLESS OTHERWISE SPECIFIED



Round Die

PART NO.	RANGE "P"	
	INCH	METRIC
XDM1	.035 - 1.575	.88 - 40.01

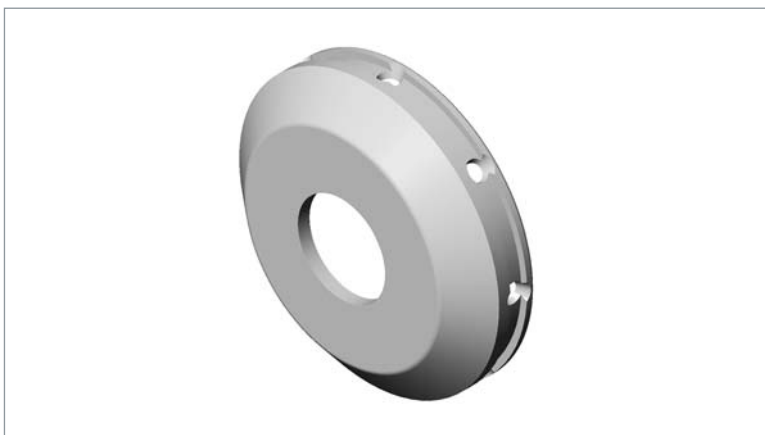

Round Stripper

PART NO.	RANGE "P"	
	INCH	METRIC
XSM1	.031 - 1.500	.78 - 38.11

Minimatic 100 / Trumatic 120® Tooling

Shape Tooling

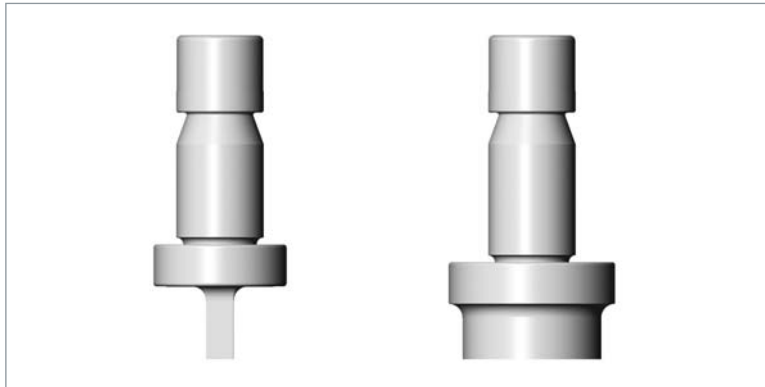

Shape Punch - Flat Face

PART NO.	RANGE - MAXIMUM ACROSS CORNER DIM.	
	INCH	METRIC
XPZ4 ___	.062 - 1.181	1.57 - 30.01
XPZ5WS ___	1.182 - 1.500	30.02 - 38.11
SPECIFY SHAPE CODE IN PLACE OF ___		



Shape Die

PART NO.	RANGE - MAXIMUM ACROSS CORNER DIM.	
	INCH	METRIC
XDMZ1 ___	.066 - 1.575	1.67 - 40.01
SPECIFY SHAPE CODE IN PLACE OF ___		



Shape Stripper

PART NO.	RANGE - MAXIMUM ACROSS CORNER DIM.	
	INCH	METRIC
XSMZ1 ___	.062 - 1.500	1.57 - 38.11
SPECIFY SHAPE CODE IN PLACE OF ___		

Minimatic 100 / Trumatic120® are Trademarks of TRUMPF GmbH&Co.

Standard Shapes and Shape Codes

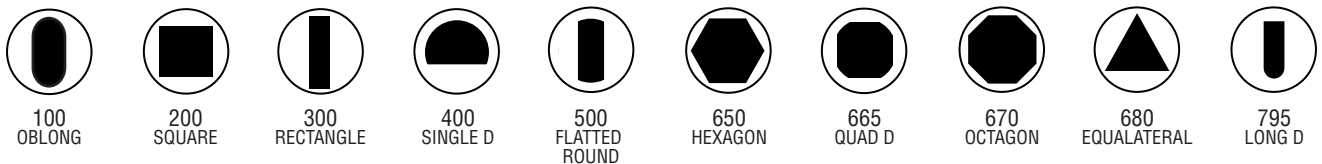

SPECIFY DIE INDEXING REQUIRED ON 400, 680 AND 795



TRUMPF® Multi-Tools

Maximum material thickness = .125" (3.2mm) mild steel

3 STATION

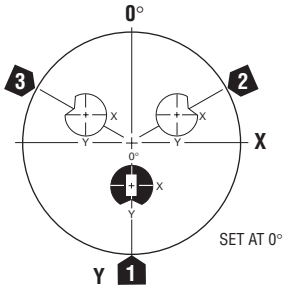

4 STATION - TOP DIE VIEW

Maximum Diameter = .630" (16.0mm)

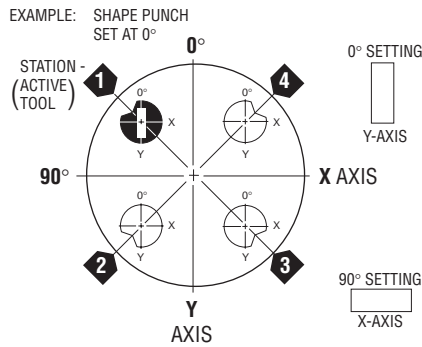

5 STATION

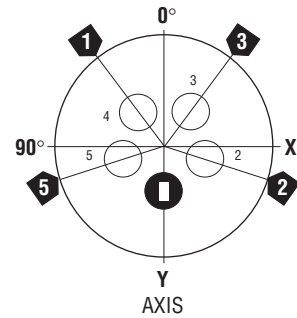

6 STATION - TOP DIE VIEW

Maximum Diameter or Diagonal = .413" (10.5mm)

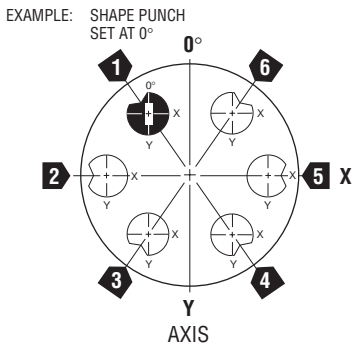

10 STATION

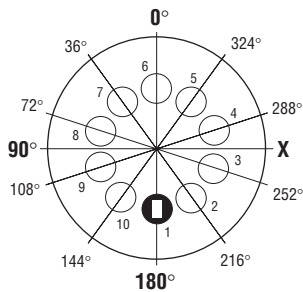

UNLESS OTHERWISE SPECIFIED ALL SHAPE TOOLS ARE MADE FOR **STATION 1**.

SPECIFY X OR Y SETTING.

SPECIAL SHAPE AVAILABLE UPON REQUEST.

Standard Shapes and Shape Codes



100
OBLONG



200
SQUARE



300
RECTANGLE



400
SINGLE D



500
FLATTED
ROUND



650
HEXAGON



665
QUAD D



670
OCTAGON



680
EQUILATERAL



795
LONG D

SPECIFY INDEXING REQUIRED ON 400, 680 AND 795

Multi-Tool Punches, Dies and Strippers

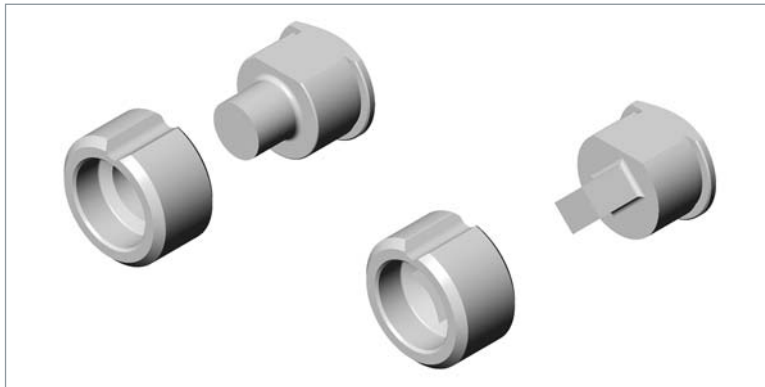

4 Station

Refer to page 8 for standard shape codes

		RANGE	
MAX. A/C .062" - .625"		1.58mm - 15.87mm	
DESCRIPTION		Wilson Ref. #	PART NO.
ROUND	PUNCH	25151	XP78
	DIE	26153	XD98
SHAPE	PUNCH	-	XPZ78 ___
	DIE	-	XDZ98 ___
SPECIFY SHAPE CODE IN PLACE OF ___			

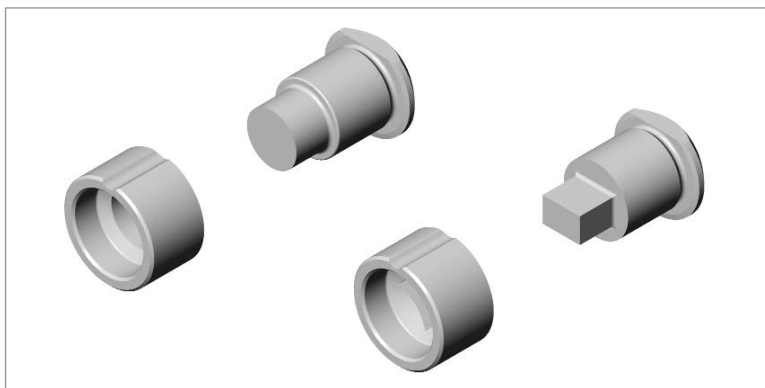

3 & 6 Station

Refer to page 8 for standard shape codes

		RANGE	
MAX. A/C .062" - .375"		1.58mm - 9.52mm	
DESCRIPTION		Wilson Ref. #	PART NO.
ROUND	PUNCH	25147	XP63
	DIE	25149	XD78
SHAPE	PUNCH	-	XPZ63 ___
	DIE	-	XDZ78 ___
SPECIFY SHAPE CODE IN PLACE OF ___			

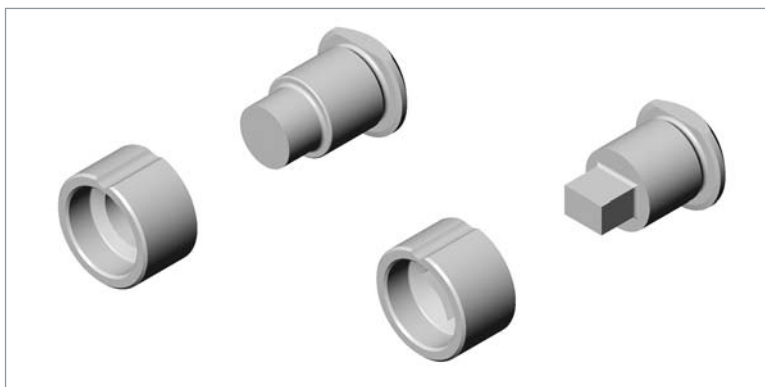

5 Station

Refer to page 8 for standard shape codes

		RANGE	
MAX. A/C .062" - .625"		1.58mm - 15.87mm	
DESCRIPTION			PART NO.
ROUND	PUNCH		XP65
	DIE		XD90
SHAPE	PUNCH		XPZ65 ___
	DIE		XDZ90 ___
SPECIFY SHAPE CODE IN PLACE OF ___			

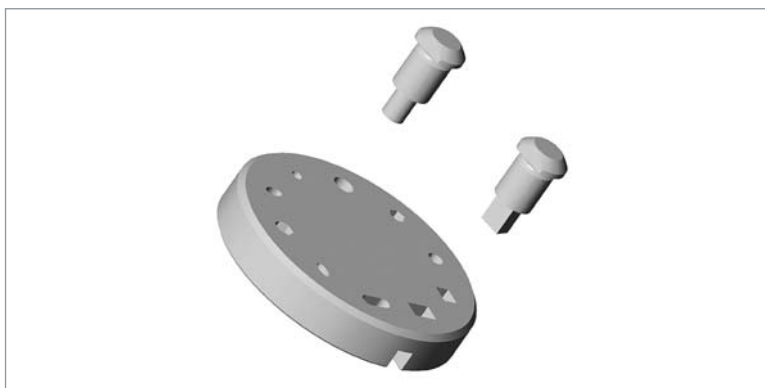

10 Station

Refer to page 8 for standard shape codes

		RANGE	
MAX. A/C .062" - .375"		1.58mm - 9.52mm	
DESCRIPTION			PART NO.
ROUND	PUNCH		XP43
	DIE		XDZ283
SHAPE	PUNCH		XPZ43 ___
	DIE		XDZ283 ___
SPECIFY SHAPE CODE IN PLACE OF ___			



Heavy Duty Tooling

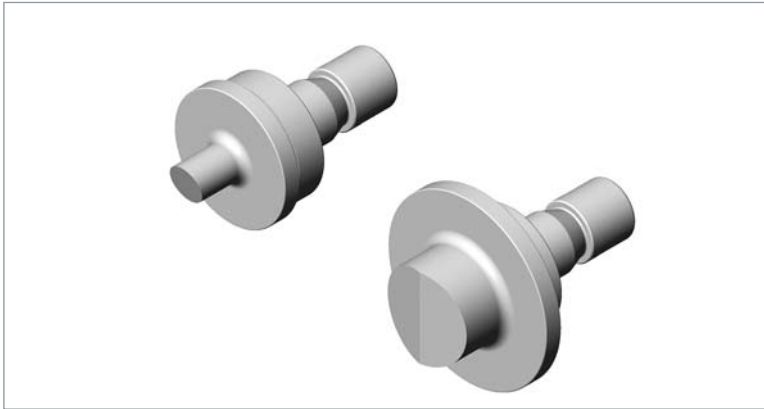

Heavy Duty - Round Punches

To punch .156" (4mm) and up mild steel/aluminum
To punch .118" (3 mm) and up stainless steel

PART NO.	RANGE "P"	
	INCH	METRIC
XP4HD	.407 - 1.181	10.33 - 30.01
XP5HD	1.182 - 1.500	30.02 - 38.11
XP6HD	1.501 - 2.015	38.12 - 51.19
XP7HD	2.016 - 2.515	51.20 - 63.89
XP8HD	2.516 - 2.760	63.90 - 70.11
XP9HD	2.761 - 3.015	70.12 - 76.59

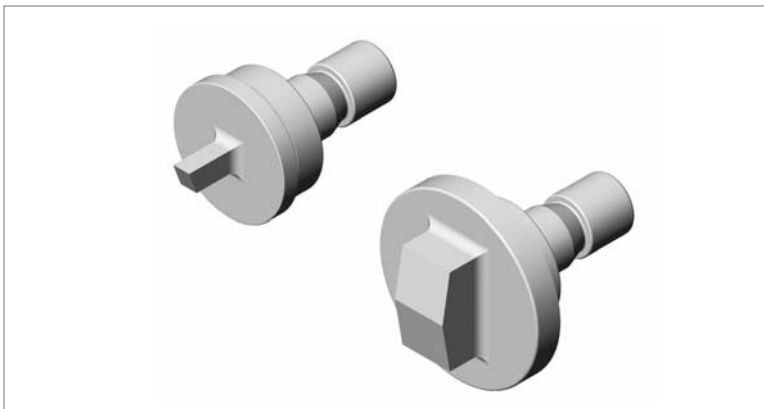

Heavy Duty - Shape Punches

.030 (.08mm) minimum radius recommended on all sharp corners.

PART NO.	RANGE "P" MAXIMUM DIM.	
	INCH	METRIC
XPZ4 ___	.250 - .406	6.35 - 10.32
XPZ4HD ___	.407 - 1.181	10.33 - 30.01
XPZ5HD ___	1.182 - 1.500	30.02 - 38.11
XPZ6HD ___	1.501 - 2.015	38.12 - 51.19
XPZ7HD ___	2.016 - 2.515	51.20 - 63.89
XPZ8HD ___	2.516 - 2.760	63.90 - 70.11
XPZ9HD ___	2.761 - 3.015	70.12 - 76.59

SPECIFY SHAPE CODE IN PLACE OF ___



Heavy Duty - Round and Shape Dies

Note: Use Standard Dies (See Pages 3 & 5) up to 20 tonnes punching pressure.

PART NO.	RANGE "P" MAXIMUM DIM.	
	INCH	METRIC
XD1HD	.407 - 1.043	10.35 - 26.50
XD2HD	1.044 - 2.126	26.51 - 54.00
*XD3HD	2.127 - 3.075	54.01 - 78.11
XDZ1HD ___	.407 - 1.043	10.35 - 26.50
XDZ2HD ___	1.044 - 2.126	26.51 - 54.00
*XDZ3HD ___	2.127 - 3.075	54.01 - 78.11

*ONLY FOR USE IN SELECTED MACHINES
SPECIFY SHAPE CODE IN PLACE OF ___

.164 AND ABOVE MATERIAL THICKNESS 30% DIE CLEARANCE RECOMMENDED

CAUTION: LARGE HOLES IN THICK OR HIGH TENSILE MATERIAL MAY EXCEED PRESS TONNAGE CAPACITY. CHECK TONNAGE.

Standard Shapes and Shape Codes

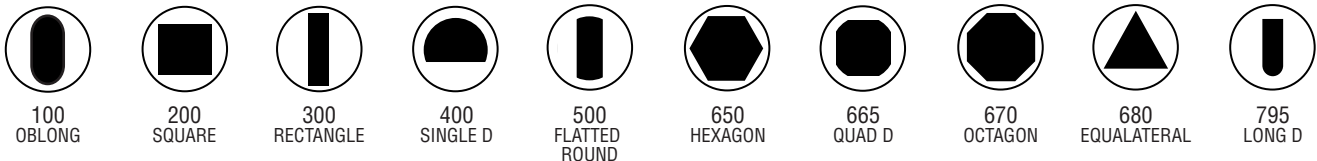

SPECIFY DIE INDEXING REQUIRED ON 400, 680 AND 795

NEW

Self Aligning Trumpf Punches

(INDEXING IS ACHIEVED WITHOUT USING AN ALIGNMENT FIXTURE)

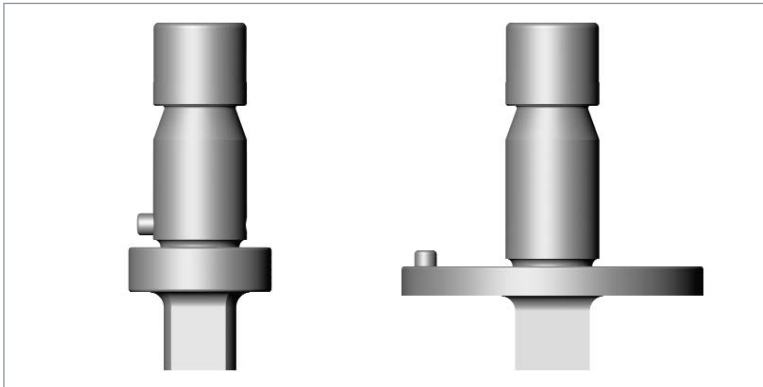

Flat Face

Punches are automatically aligned at 0° or 90° in the new alignment ring.

PART NO.	RANGE - MAXIMUM ACROSS CORNER DIM.	
	INCH	METRIC
*XPZP4 ___	.062 - 1.181	1.57 - 30.01
XPZP5 ___	1.182 - 1.500	30.02 - 38.11
XPZP6 ___	1.501 - 2.015	38.12 - 51.19
XPZP7 ___	2.016 - 2.515	51.20 - 63.89
XPZP8 ___	2.516 - 2.760	63.90 - 70.11
XPZP9 ___	2.761 - 3.015	70.12 - 76.59

*SUPPLIED AS STANDARD UNLESS OTHERWISE SPECIFIED

SPECIFY SHAPE CODE IN PLACE OF ___

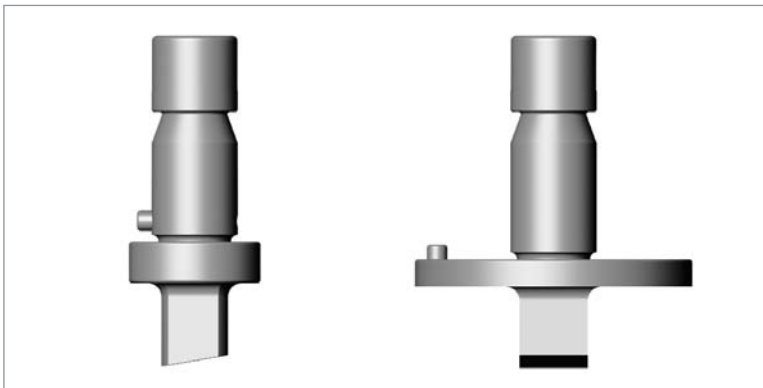

Whisper Shear®

Punches are automatically aligned at 0° or 90° in the new alignment ring.

PART NO.	RANGE - MAXIMUM ACROSS CORNER DIM.	
	INCH	METRIC
XPZP4WS ___	.062 - 1.181	1.57 - 30.01
*XPZP5WS ___	1.182 - 1.500	30.02 - 38.11
*XPZP6WS ___	1.501 - 2.015	38.12 - 51.19
*XPZP7WS ___	2.016 - 2.515	51.20 - 63.89
*XPZP8WS ___	2.516 - 2.760	63.90 - 70.11
*XPZP9WS ___	2.761 - 3.015	70.12 - 76.59

*SUPPLIED AS STANDARD UNLESS OTHERWISE SPECIFIED

SPECIFY SHAPE CODE IN PLACE OF ___

Whisper Shear is a Trademark of TRUMPF GmbH&Co.

KEYWAYS AT 0° AND 90° IN THE ALIGNING RING ACCURATELY ALIGNS THE SHAPE PUNCH, WHICH HAS A DOWEL ON THE BODY.

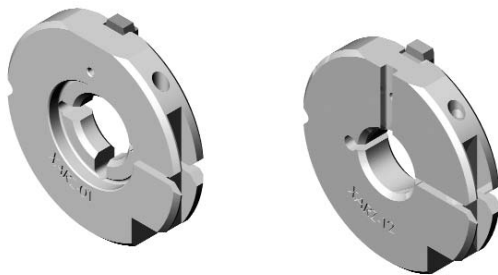

Universal Alignment Ring

The integral keyways allow for accurate alignment of the punch and faster machine set-up without an alignment fixture.

For TC20, TC20A, C15, CS20, CS20A, CN1200A, CN1200S, 202M, MP25; CN700/900, CN701/901, CN901E, CN902, CS75

PART NO.	TOOL STYLE	RANGE "P" - MAXIMUM DIM.	
		INCH	METRIC
XARP-01	STANDARD	UP TO 1.181	30.01
XARP-12	STANDARD	1.182 AND UP	30.02

WHEN A SHAPE PUNCH IS REQUIRED AT OTHER THAN 0 OR 90 DEGREES, EXACTA CAN SUPPLY THE SHAPED INDEXED AT ANY ANGLE

Standard Shapes and Shape Codes

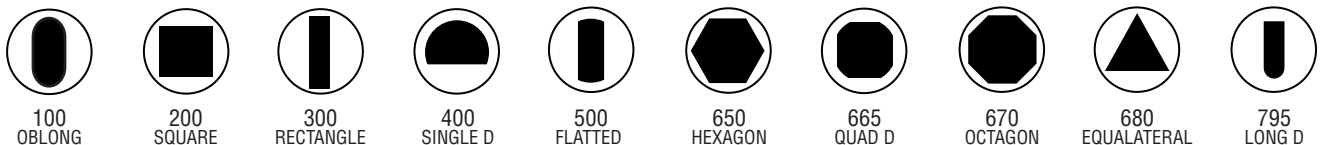

SPECIFY INDEXING REQUIRED ON 400, 680 AND 795

Tooling Accessories



Standard Die Adaptors

Die adaptors are for enlarging the OD of small dies for use in larger die bases.

DIE SIZE CONVERSION	PART NO.	REFERENCE NUMBERS		
SMALL TO MEDIUM	XDA1-2	7336-1ZM/02*	25165	MAT20000
SMALL TO LARGE	XDA1-3	7336-1ZM/03	25168	MAT40000
MEDIUM TO LARGE	XDA2-3	7336-2ZM/02	25167	MAT30000
*FOR CN 700/900, CN701/901, C901E, CN902 CS 75	XDAZ1-2	7336-1ZM/04	-	-

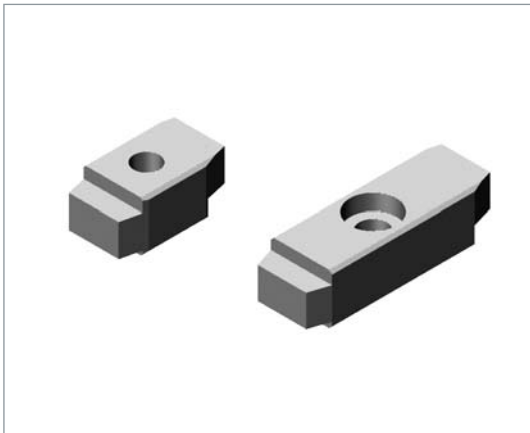

Tool Length Compensation Keys

These keys will allow you to automatically compensate for different tool lengths after regrinding, to provide proper punch penetration.

MACHINE MODELS	PART NO.	REFERENCE NUMBERS		
202W, 300W, 300PW, 400W	XCK1	7336-2818	-	-
		- FOR STANDARD VERSION PUNCHES		
	XCKH1	-	-	-
		- FOR REINFORCED VERSION PUNCHES		



Stripper Adaptor Rings

Adaptor rings adapt the listed machines to accept small strippers.

MACHINE MODELS	PART NO.	REFERENCE NUMBERS		
TC20, TC20A, 202M, TC202W, 300W, CS20	XSA2	7336-2ZA/02	-	-
TC20W, TC202W, TC300W, TC400W, 20AW, 300LW, 300TOP, 300PW	XSA3	7336-2ZA/03	25155	-

Tooling Accessories



Alignment Rings

Alignment rings provide support and proper orientation for punches.

For TC20, TC20A, C15, CS20, CS20A, CN1200A, CN1200S, 202M, MP25; CN700/900, CN701/901, CN901E, CN902, CS75

TOOL STYLE	DIAMETER	PART NO.	REFERENCE NUMBERS		
STANDARD	UP TO 1.181"	XAR01	7336-0JS/01	25197	VANTD
STANDARD	1.182" AND UP	XAR12	7336-1JS/01	25198	VAPTD
HEAVY DUTY	UP TO .406"	XAR01	7336-0JS/01	25197	VANTD

Alignment Rings

Alignment rings provide support and proper orientation for punches.

For TC150K, 180K, 180LK, 180PK, 202K, 300K, 300PK, 400K; 150W, 180W, 185, 180WD, 180LW, 225, 235, 240, 260, 202W, 300W, 300PW, 400W

TOOL STYLE	DIAMETER	PART NO.	REFERENCE NUMBERS		
STANDARD	UP TO 1.181"	XAR02	7336-0JS/02	25018	VANTE
STANDARD	1.182" AND UP	XAR22	7336-1JS/02	25139	VAPTE
HEAVY DUTY	UP TO .406"	XAR02	7336-0JS/02	25018	VANTE
HEAVY DUTY	407" AND UP	XAR11	7336-1JS/04	25138	VANTF

NEW for Self Aligning Punch Alignment Rings see page 11

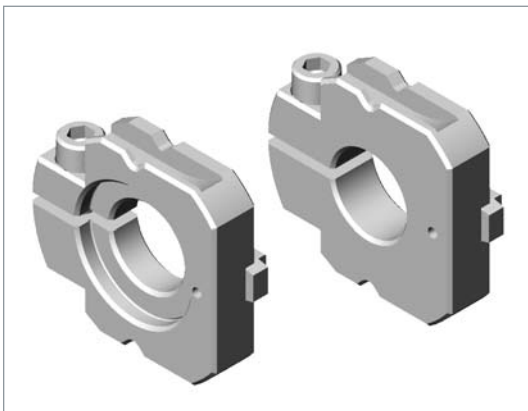

Minimatic 100 / Trumatic 120 Alignment Rings

Alignment rings provide support and proper orientation for punches.

TOOL STYLE	DIAMETER	PART NO.	REFERENCE NUMBERS		
STANDARD	TO 1.181	XARM1	7336-0JS/06	25186	VANTM
STANDARD	OVER 1.182	XARM2	7336-1JS/06	25188	VAPTM

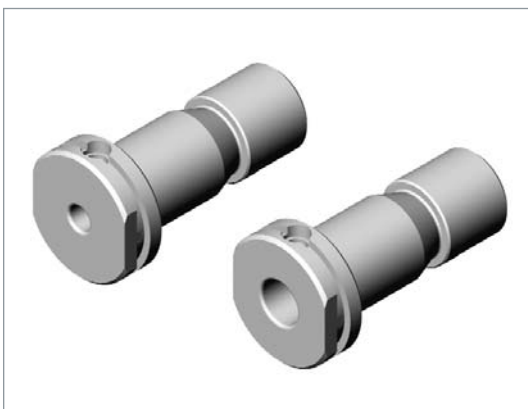

Punch Chucks (Insert Holders)

Punch chucks provide support for small (XP1, XP2 & XP3) punches.

PUNCH SIZE DIAMETER	PART NO.	REFERENCE NUMBERS		
UP TO .234"	XPC2	7336-OSF10/03	25010	VINTS010
.235 TO .406	XPC3	7336-OSF20/03	25021	VINTS020

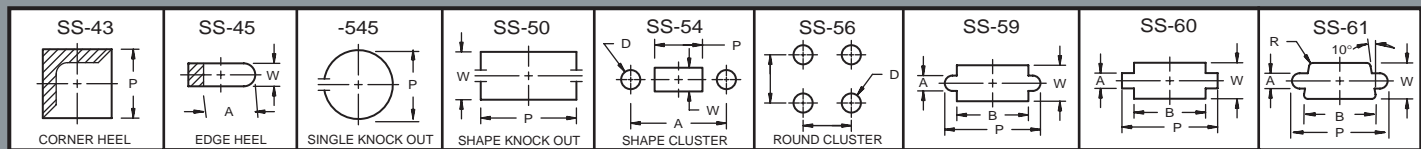

Forming Tools

EXAMPLES AND SHAPE CODES

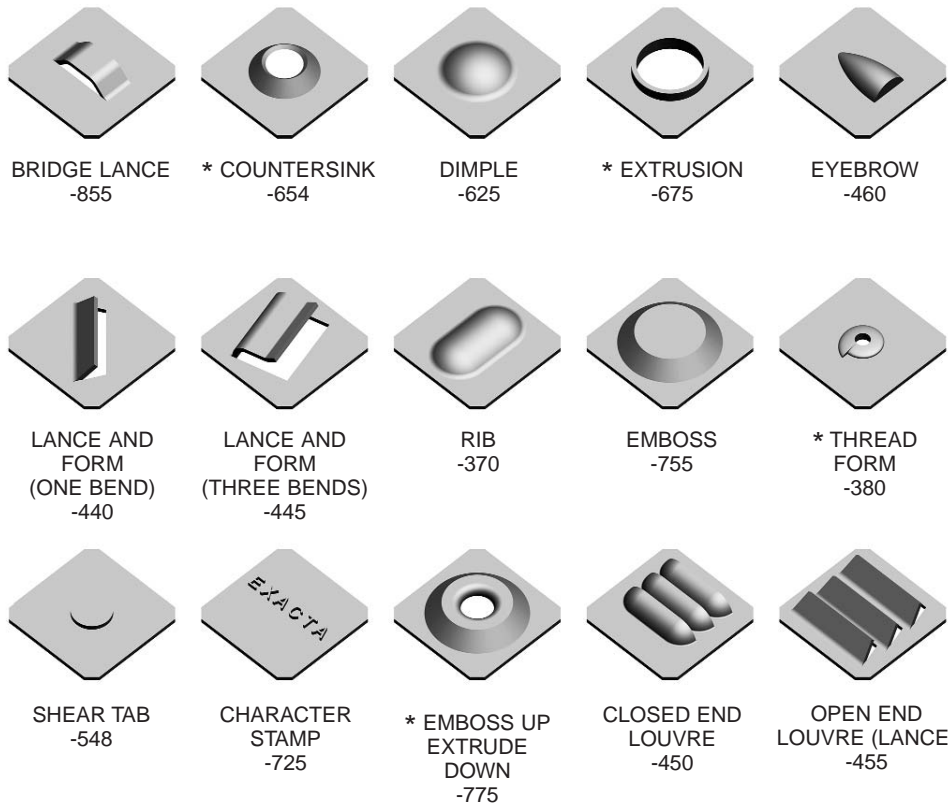

*MUST HAVE PRE PIERCED HOLE

Ordering Information

1. Applicable **SHAPE CODE** _ _ _
2. Machine Model
3. Material Type
4. Material Thickness
5. Form Up or Form Down
6. Hole Pattern (if applicable)
7. Dimensioned Drawing or Sketch
8. Specify Keying

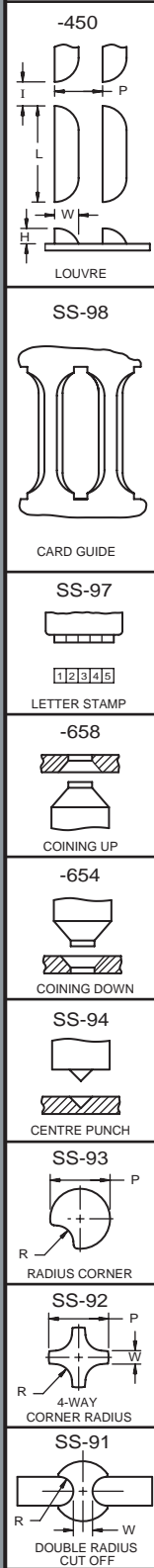
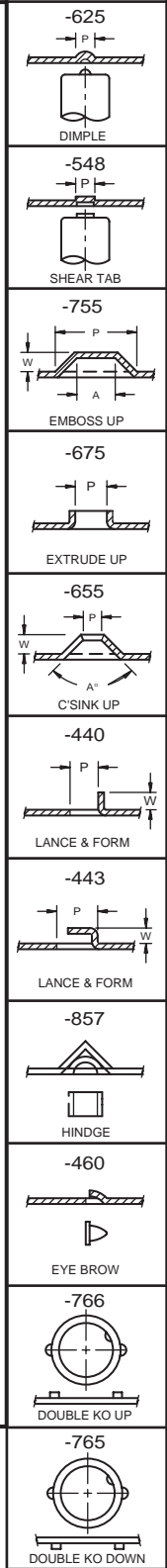

Exacta Precision Products Ltd.
3115 Kennedy Road
Scarborough, Ontario, Canada
M1V 4Y1

Telephone: (416) 291-1942
Toll Free: 1-800-268-5573
Fax: (416) 291-8387
Toll Free Fax: 1-800-668-9314



TORONTO

Exacta Produits de Précision Ltée.
5965 Chemin St. François
Ville St. Laurent, Québec, Canada
H4S 1B6

Téléphone: (514) 333-0146
(Aucun Frais): 1-800-361-6810
Québec, N.B., .P.E.I. & N.S. (Toll Free)
Télécopieur: (514) 333-0147



Website: www.exactapunch.com • E-mail: info@exactapunch.com

